



Feature:

- Yellow diffused lens
- Long operating life
- Middle power consumption and wide viewing angle 120 deg.
- This product doesn't contain restriction Substance, comply ROHS standard

Description:

2016 series with heat sink design, compact design, suitable for indoor and outdoor application.

Application:

- Decoration lighting
- Motormeter
- Backlight
- Indicator

Certification & Compliance:

- ISO9001
- RoHS Compliant



Dimension:

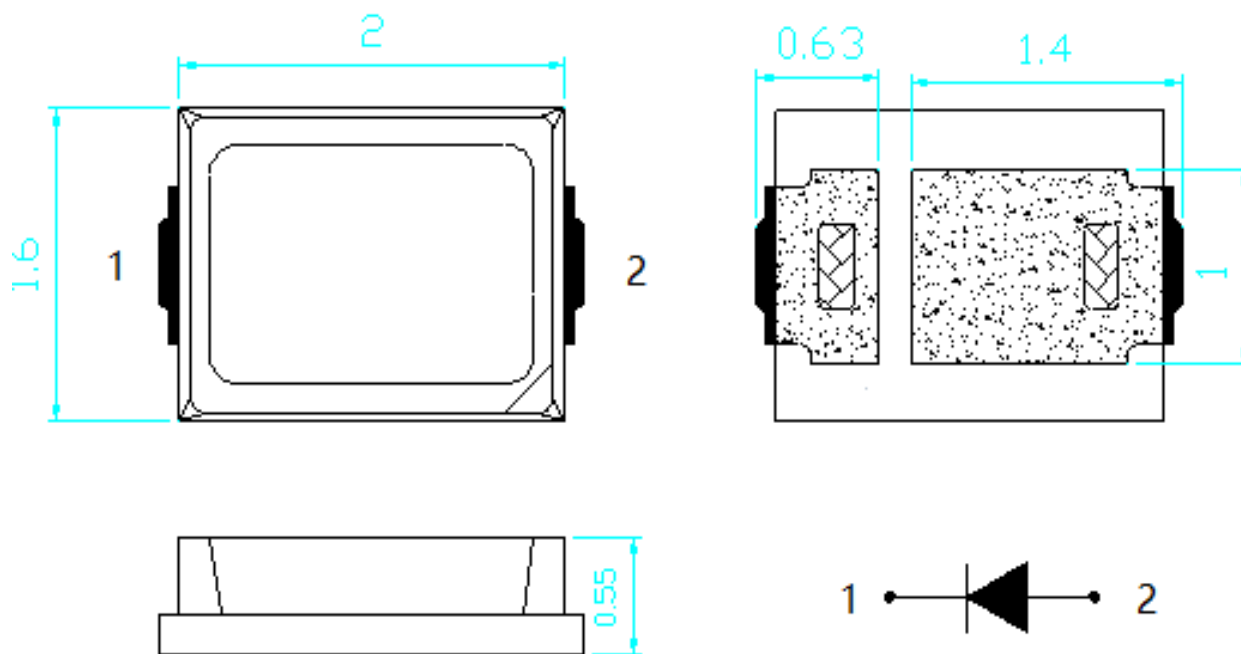

Notes:

1. All dimensions are in millimeters .
2. All dimensions tolerance is ± 0.2 mm unless otherwise noted.



Electrical / Optical Characteristic (T=25 °C)

Parameter	Symbol	Test Conditions	Min.	Typ.	Max.	Tolerance	Unit
Luminous Flux	Φ	IF=3mA	1.5	--	1.8	±5%	Lm
Luminous Efficiency	ηL	IF=3mA	165	--	180	±100	Lm/w
Luminous Intensity	IV	IF=3mA	300	--	450	±10%	mcd
Forward voltage	VF	IF=3mA	2.5	2.6	2.8	± 0.1	V
Reverse leakage current	IR	VR=5V	--	--	10	±0.1	μA
Color Temperature	Tc	IF=3mA	6000	--	6800	±100	K
Color rendering index	Ra	IF=3mA	70	--	--	±1	/

Absolute Maximum Rating (T=25 °C)

Parameter	Symbol	Absolute maximum Rating	Unit
Constant Forward Current	IF	60	mA
Peak Forward Current	IFP	150	mA
Reverse Voltage	VR	5	V
Operation Temperature	Topr	-25 ~ 85	°C
Storage Temperature	Tstg	-40 ~ 100	°C
Junction Temperature	Tj	115	°C
Reflow Peak Temperature	Tsol	< 10S @260°C	°C
Electrostatic Discharge Classification	ESD	2000 V	

1. For other ambient, limited setting of current will depend on de-rating curves.
2. D=0.01s duty 1/10.
3. When drive on maximum current , Tj must be kept below 115°C

VF Bins@IF=3mA

VF Bins	Bin	Min.	Max.	Unit
	V1	2.5	2.6	V
	V2	2.6	2.7	
	V3	2.7	2.8	



IV Bins@3mA

IV Bins	Bin	Min.	Max.	Unit
	M1	300	350	mcd
	M2	350	400	
	M3	400	450	

CIE Chromaticity Diagram

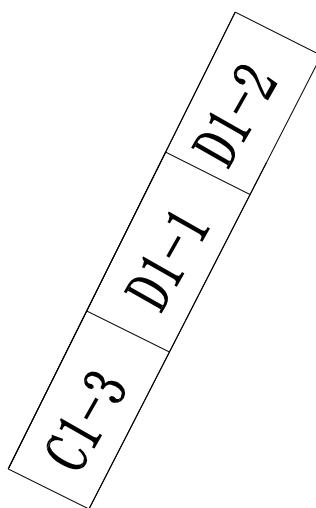

BIN	X1	Y1	X2	Y2	X3	Y3	X4	Y4
C1-3	0.2999	0.3174	0.3065	0.3144	0.3051	0.3284	0.3117	0.3252
D1-1	0.3051	0.3284	0.3117	0.3252	0.3102	0.3392	0.3169	0.3360
D1-2	0.3102	0.3392	0.3169	0.3360	0.3153	0.3501	0.3222	0.3468



Characteristic Curves:

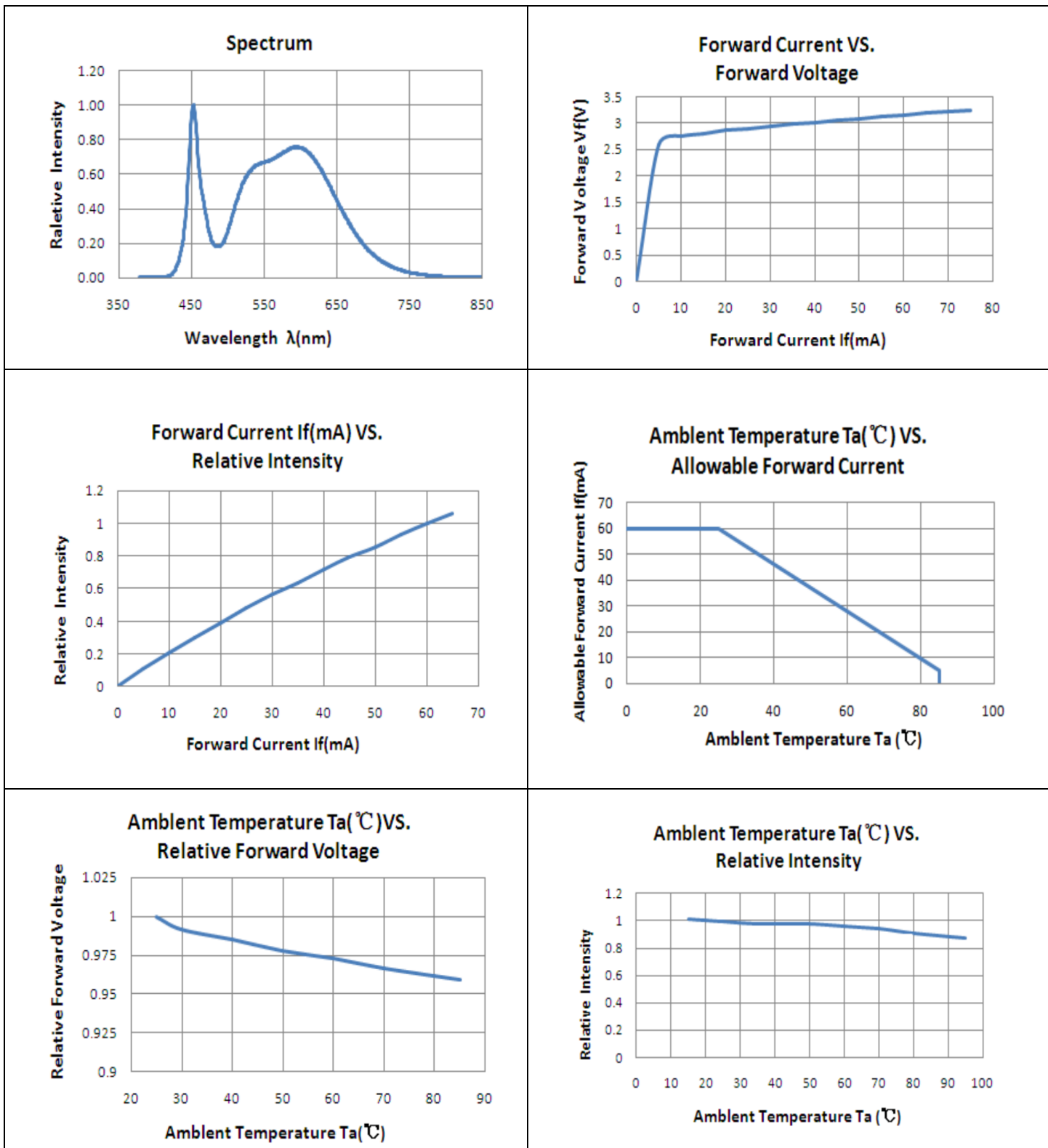



Soldering Profile

- Recommended tin glue specifications: melting temperature in the range of 178~192 °C
- The recommended reflow soldering profile is as follows (temperatures indicated are as measured on the surface of the LED resin):

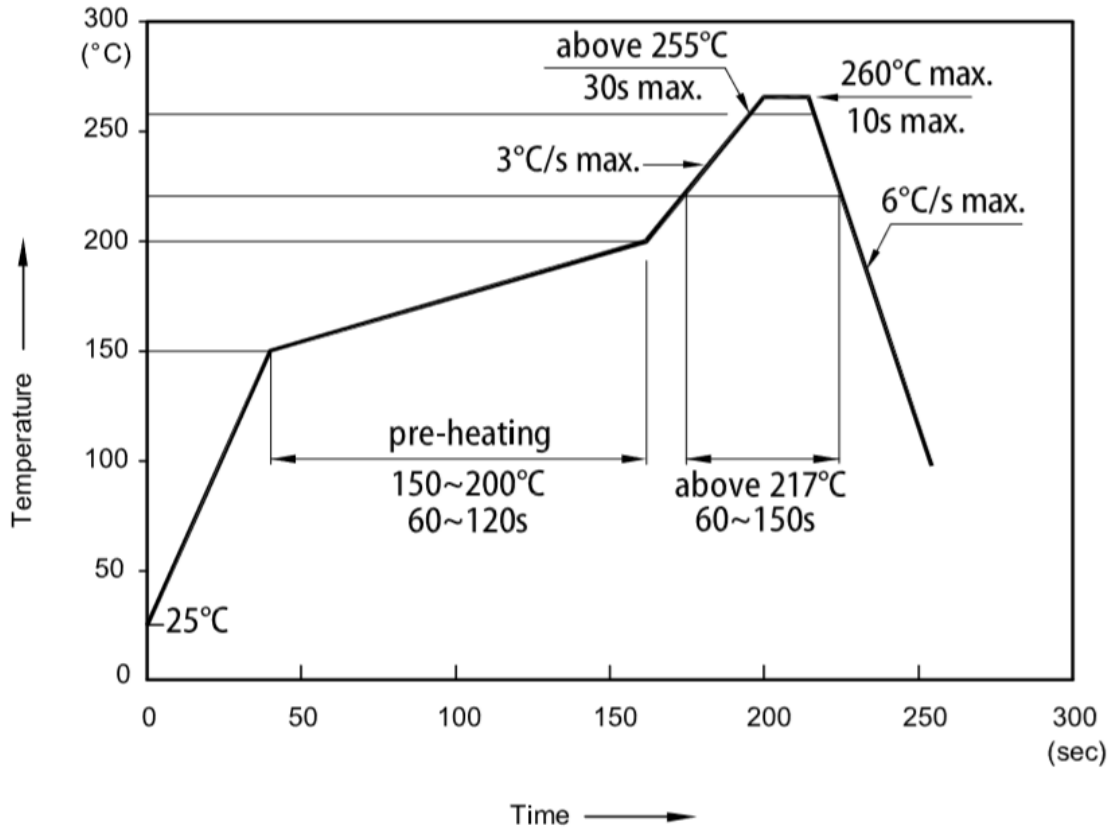

1. Reflow soldering should not be done more than two times.
Many times reflow soldering has destructive effect to the product.
2. When soldering, do not stress on the LEDs during heating.



Reliability test items and conditions:

NO	Item	Test Conditions	Time	Quantity	Ac/Re
1	IR-Reflow	TEMP : 240°C ± 5 °C	10 Sec	22 PCS	0/1
2	Temperature Cycle	H : +100°C 15min ∫ 5 min L : -40°C 15min	300 Cycles	22 PCS	0/1
3	Thermal Shock	-40°C (30min) -100°C (30min)	100 Cycles	22 PCS	0/1
4	High Temperature Storage	TEMP : 100°C	1000 Hrs	22 PCS	0/1
5	Low Temperature Storage	TEMP : -40°C	1000 Hrs	22 PCS	0/1
6	DC Operating Life	TEMP : 25°C	1000 Hrs	22 PCS	0/1
		IF =60mA			
7	High Temperature / High Humidity	60°C / 90% RH	1000 Hrs	22 PCS	0/1

The technical information shown in the data sheets are limited to the typical characteristics and circuit examples of the referenced products. It does not constitute the warranting of industrial property nor the granting of any license.

Criteria For Judging Damage

Item	Symbol	Test Conditions	Criteria for Judgement	
			Min	Max
Forward Voltage	VF	IF=60mA		U.S.L*)x1.1
Reverse Current	IR	VR=5V		U.S.L*)x2.0
Luminous Flux	LM	IF=60mA	L.S.L*)x0.7	

U.S.L: Upper standard level

L.S.L: Lower standard level



■ Instructions Of Soldering

1. Hand Solder should not be using hand soldering iron, suggest using heating operation, the use of solder paste melting point under 220 °C, the heating temperature set less than or equal to 240 °C, the time is not more than 10s, a welding is complete, multiple welding products are destructive.
2. Handle the component along the side surface by using forceps or appropriate tools; do not directly touch or Handle the silicone lens surface, it may damage the internal circuitry.

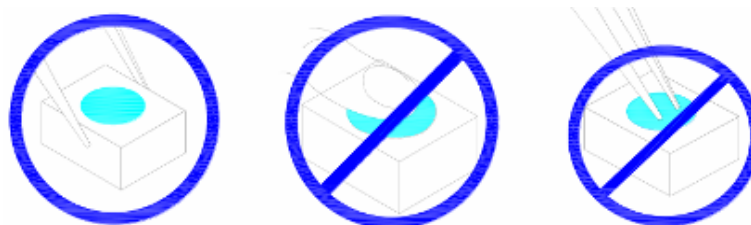

■ Cautions

Storage condition

1. The operation of Temperatures and RH are : $\leq 30^{\circ}\text{C}$, RH<60%.
2. Once the package is opened, the products should be used within 8hours, Otherwise, more than the dehumidification process, dehumidifying conditions: reel 70 °C / 6 ~ 8 h, bulk LED150 °C / 3 h
3. Considering the operation environment of temperature and humidity ,we suggest our customers to use our products within three months (from production date), More than 3 months with toasted constant temperature 70 °C \pm 5 °C for 6 ~ 8 hours desiccant (need to get rid of aluminum foil bag packing).
4. The outer diameter of the SMD pickup nozzle should not exceed the size of the LED to prevent air leaks. The inner diameter of the nozzle should be as large as possible. A pliable material is suggested for the nozzle tip to avoid scratching or damaging the LED surface during pickup. The dimensions of the component must be accurately programmed in the pick-and-place machine to insure precise pickup and avoid damage during production.

Product: S20161-WCDPR-02	Date: Jul 11th, 2019	Page 7 of 8
	Version# 1.2	



5. LED operating environment and sulfur element composition cannot be over 100PPM in the LED contact usage material.



6. When external glue needed for LED application products, please make sure that the external glue matches the LED packaging glue. As most of LED packaging glue is silica gel, and it has strong Oxygen permeability as well as strong moisture permeability; in order to prevent external material from getting into the inside of LED, which may cause the malfunction of LED, the single content of Bromine element is required to be less than 900PPM, the single content of Chlorine element is required to be less than 900PPM, the total content of Bromine element and Chlorine element in the external glue of the application products is required to be less than 1500PPM

7. Please note that the electrostatic protection during processing, All devices, equipment and machinery must be properly grounded.

Products use manual

1. LED unfavorable use by constant voltage or more LED directly to the parallel use, advising clients to use in constant current mode.
2. When using LED products, please note that according to the grades of the same (voltage, brightness, color temperature) code together, different grades and different batches should be confirmed to meet customers' requirements to mix stick, lest produce color difference or brightness difference.

Part Numbering Code

S	2016	1	W	C	DPR	02
SMD Type	Lead frame size	Chip qty	Color	nm/CCT	Chip Code	Version



Part Number Coding

CODING SCHEME

<u>X</u>	<u>XXXX</u>	<u>X</u>	<u>X</u>	<u>XXX</u>	<u>X</u>	<u>XX</u>
S - SMD Type P - PCB Type L - Lamp Type HP - High Power Type M - LED Module Type F - Fixture Type	Lead Frame Size	Chip Qty	Emitting Color - W - White B - Blue S - Sensor N - Not visible	Pd(watt)/nm/CCT Pd - 01 - 1W nm (ref.) - 365 - 365nm 470 - 470nm 660 - 660nm CCT - W - Warm White N - Netruel White C - Cool White	Chip Code	Version

Note

The information in this document provides generic information but for specific information on a product the appropriate product datasheet should be used.