



**Feature:**

- 60 degree lens
- Big heat sink design
- Perform better on uniform

**Description:**

Special design PLCC2 2835 lead frame, 60 degree viewing angle, with heat sink design; High brightness intensity for directional light sources.

**Application:**

- Outdoor Display
- CCD Lighting
- Traffic Signal

**Certification & Compliance:**

- ISO9001
- RoHS Compliant



**Dimension:**

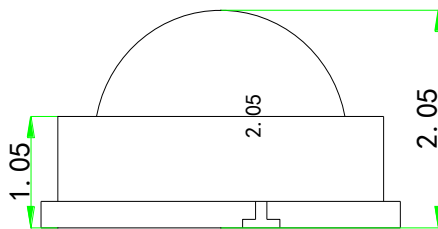
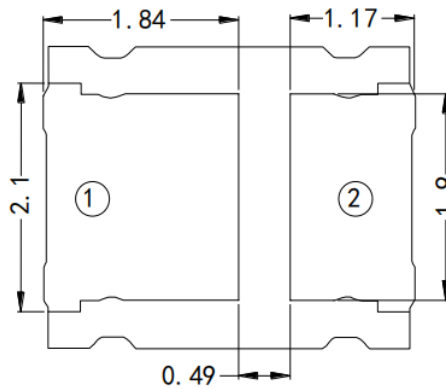
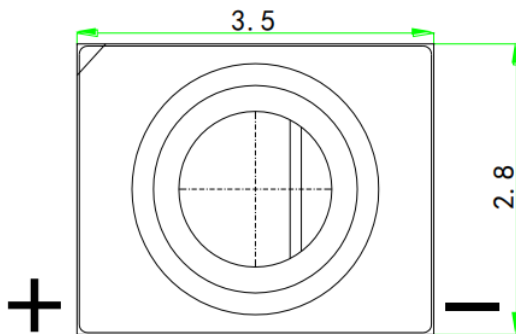

**Recommended Soldering Pattern**

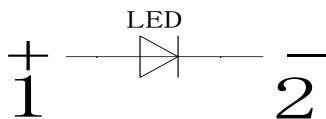
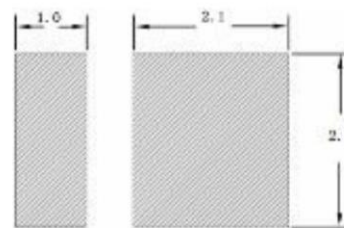

**Remark:**

1. All dimensions are in millimeters
2. Tolerance = +/-0.1mm

**Electrical / Optical Characteristic** (T=25 °C)

Parameter	Symbol	Test Conditions	Min.	Typ.	Max.	Tolerance	Unit
Forward Voltage	V <sub>F</sub>	I <sub>F</sub> =100mA	1.5	--	1.8	± 0.1	V
Luminous Flux	Im	I <sub>F</sub> =100mA	60	--	100		lm
Reverse Current	I <sub>R</sub>	V <sub>R</sub> =5V	--	--	5	±0.1	μA
Viewing Angle	°	I <sub>F</sub> =100mA	--	60	--	±10	°
Dominant Wavelength	λ <sub>D</sub>	I <sub>F</sub> =100mA	845	--	855	±1	nm
Spectrum line half width	Δλ	I <sub>F</sub> =100mA	--	35	--	/	nm

**Absolute Maximum Rating**

Parameter	Symbol	Rating	Unit
Peak forward current	I <sub>F</sub>	100	mA
Power Dissipation	P <sub>d</sub>	0.18	W
Reverse Voltage	V <sub>R</sub>	5	V
Electrostatic Discharge	ESD	2000	V
Operating Temperature	T <sub>opr</sub>	-45~+85	°C
Storage Temperature	T <sub>stg</sub>	-40~+100	°C

\*\* IR Reflow for no more than 10 sec @ 255±5°C



### OPTICAL CHARACTERISTIC CURVES

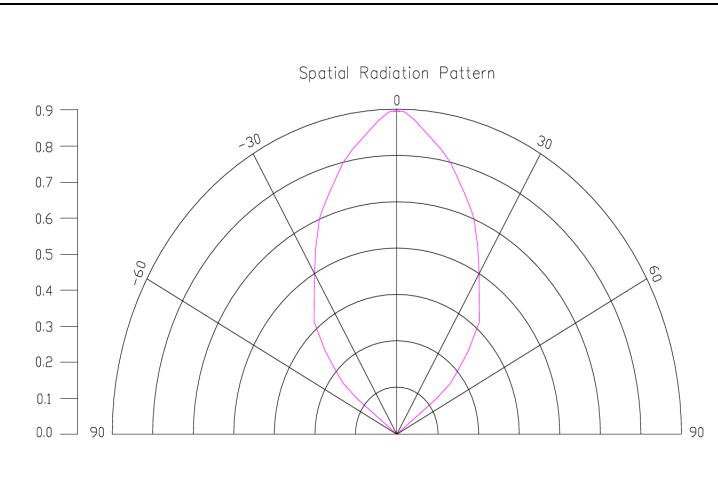
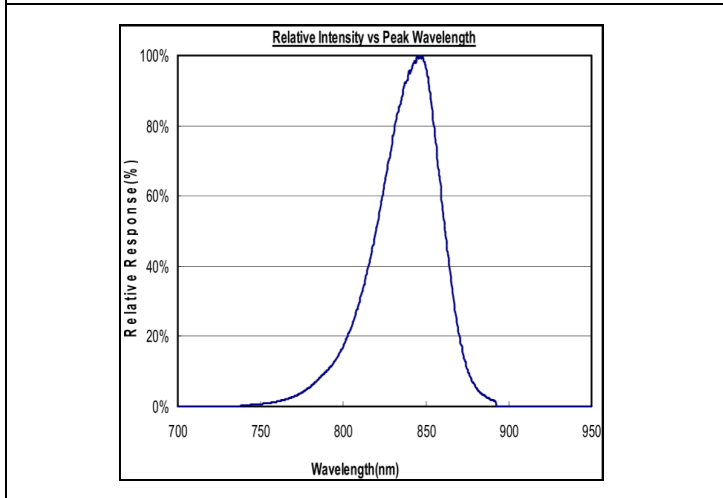
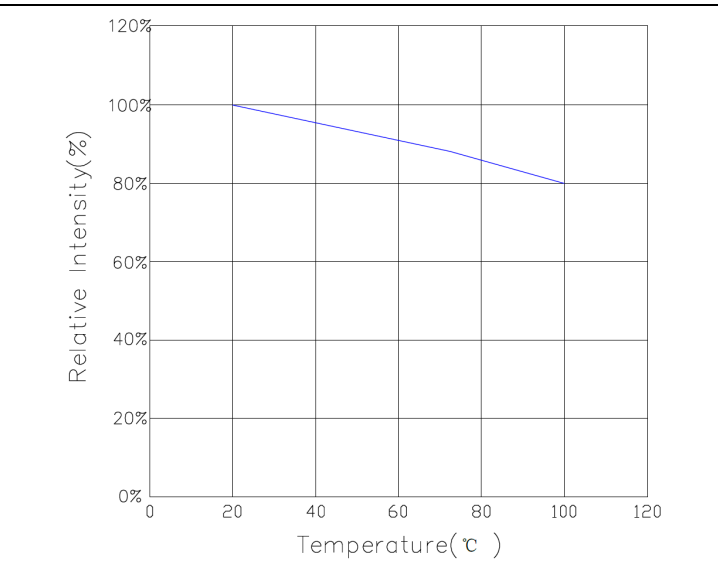
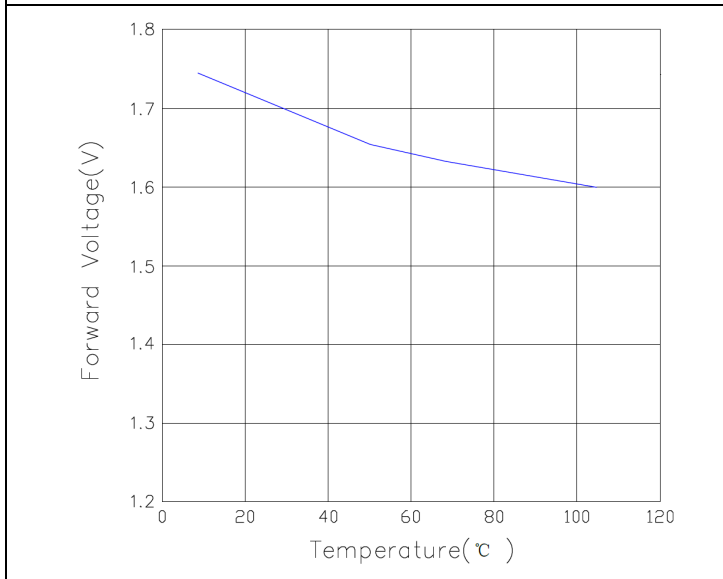
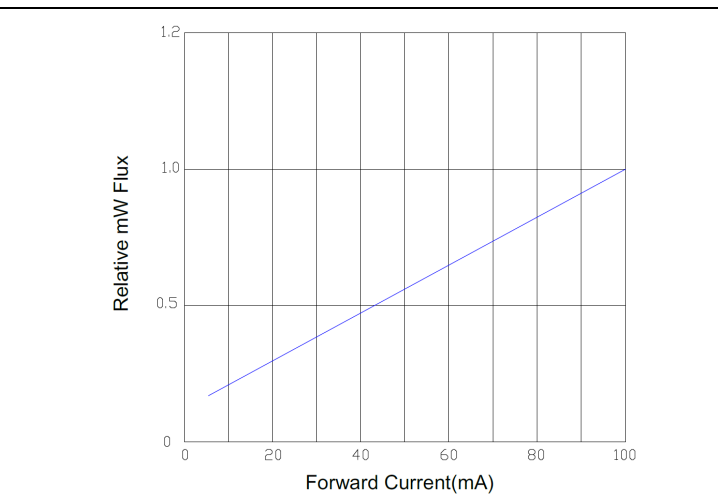
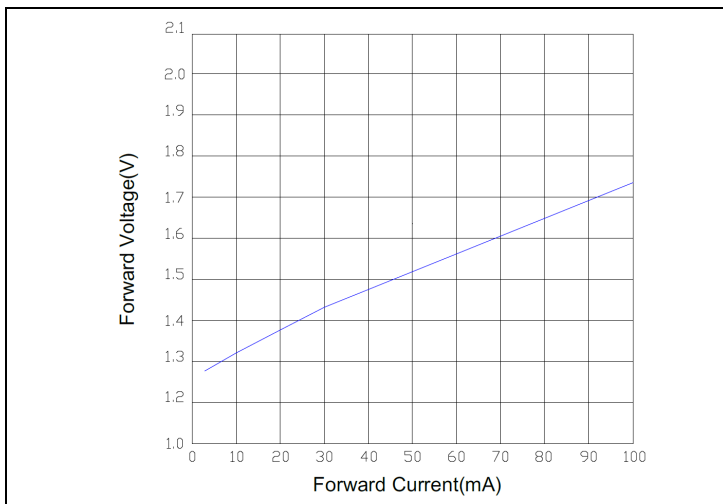



### Soldering temperature curve chart (Reflow solder profile)

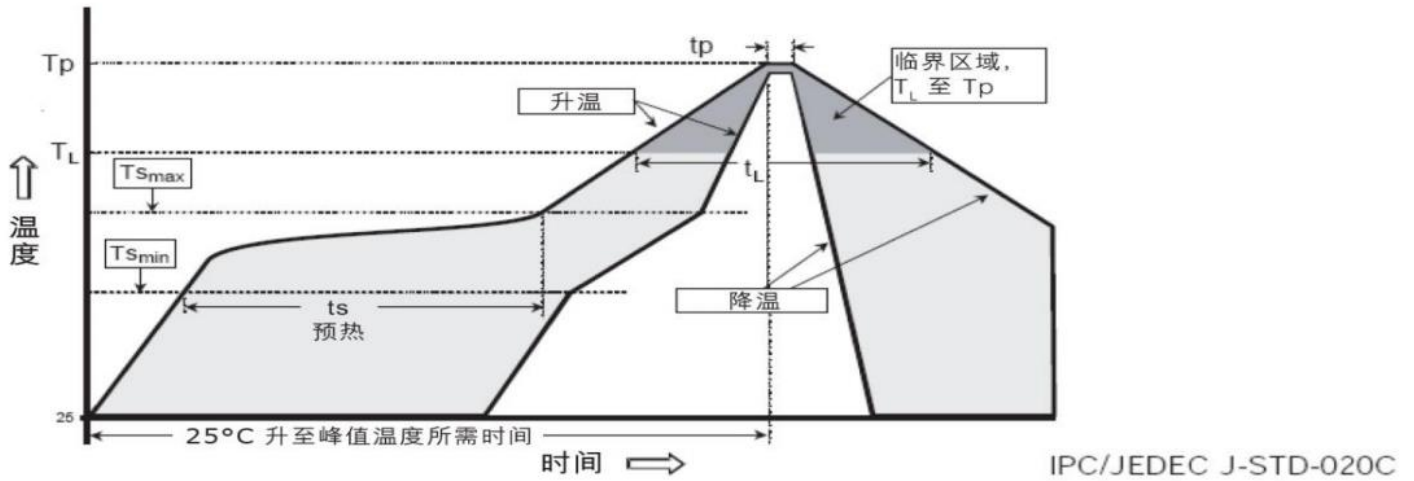

温度曲线特点	铅基焊料	无铅焊料
平均升温速度 (Ts <sub>max</sub> 至 Tp)	最高 3°C/秒	最高 3°C/秒
预热: 最低温度 (Ts <sub>min</sub> )	100°C	150°C
预热: 最高温度 (Ts <sub>max</sub> )	150°C	200°C
预热: 时间 (ts <sub>min</sub> 至 ts <sub>max</sub> )	60-120 秒	60-180 秒
维持高于温度的时间: 温度 (T <sub>L</sub> )	183°C	217°C
维持高于温度的时间: 温度 (t <sub>L</sub> )	60-150 秒	60-150 秒
峰值/分类温度 (Tp)	215°C	260°C
在实际峰值温度 (tp) 5°C 内的时间	10-30 秒	20-40 秒
降温速度	最高 6°C/秒	最高 6°C/秒
25°C 升至峰值温度所需时间	最多 6 分钟	最多 8 分钟

1. Reflow soldering should not be done more than two times. many times reflow soldering has destructive effect to the product
2. When soldering , do not put stress on the LEDs during heating



**Packing:**

1. Tape leader and reel

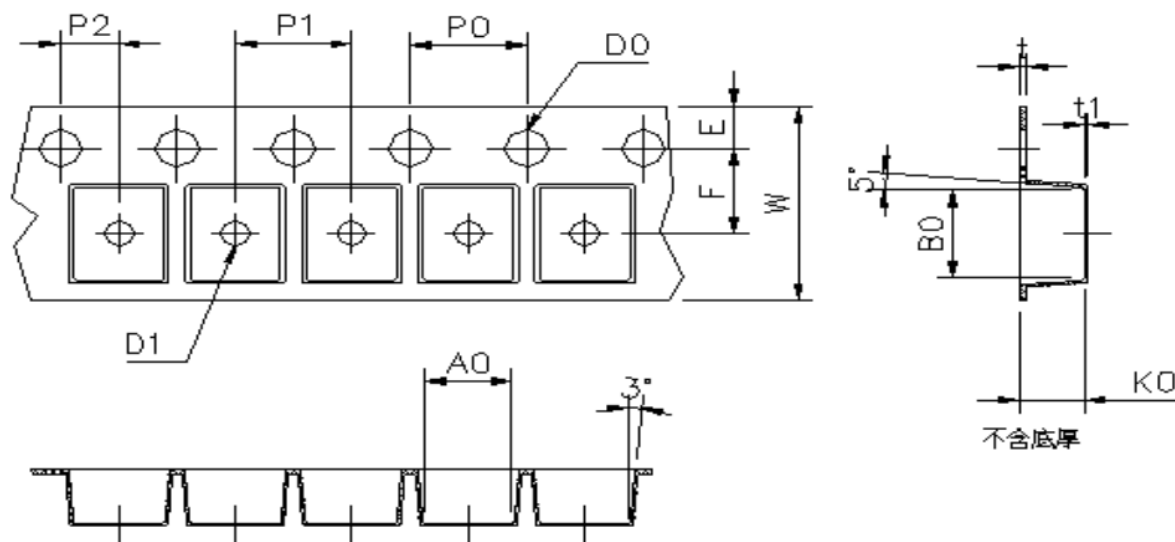

Symbol	Spec	Symbol	Spec
W	8.00 ± 0.10	A <sub>0</sub>	3.05 ± 0.10
E	1.75 ± 0.10	B <sub>0</sub>	3.60 ± 0.10
F	3.50 ± 0.05	K <sub>0</sub>	2.750 ± 0.10
D <sub>0</sub>	1.55 ± 0.05	P <sub>2</sub>	2.00 ± 0.10
D <sub>1</sub>	1.10 ± 0.10	t	0.23—0.25
P <sub>0</sub>	4.00 ± 0.10	t <sub>1</sub>	0.05 以上
P <sub>1</sub>	4.00 ± 0.10		

Note: The tolerances unless mentioned is ±0.1mm , Unit: mm

**Reel Specifications (Units : mm)**

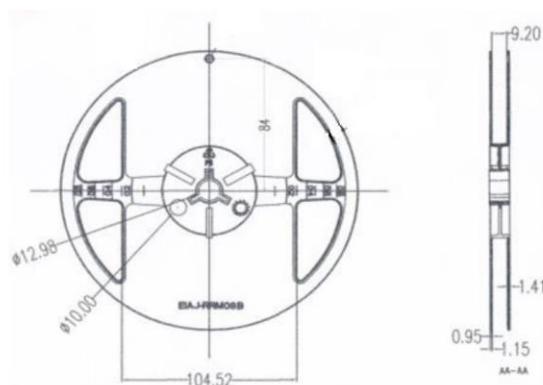



## Moisture Resistant Packaging

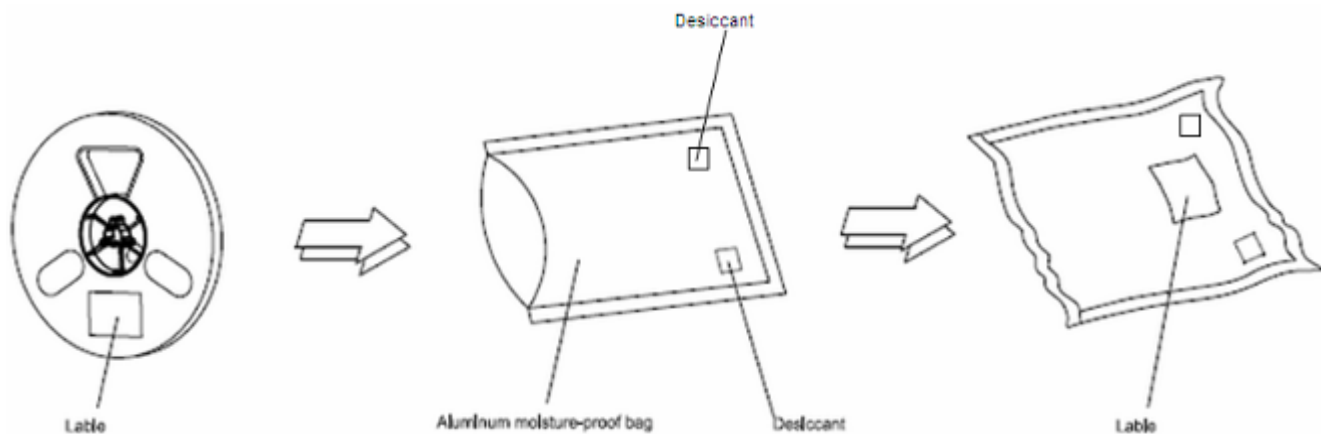

### Storage:

1. The operation of Temperatures and RH are :  $\cong 30^{\circ}\text{C}$ , RH<60%.
2. Once the package is opened, the products should be used within 8 hours, Otherwise, more than the shelf time, baking conditions: reel  $70^{\circ}\text{C}$  / 6 ~ 8 h, bulk LED  $150^{\circ}\text{C}$  / 3 h
3. Considering the operation environment of temperature and humidity ,we suggest our customers to use our products within three months (from production date), More than 3 months with toasted constant temperature  $70^{\circ}\text{C} \pm 5^{\circ}\text{C}$  for 6 ~ 8 hours desiccant (need to get rid of aluminum foil bag packing).
4. The outer diameter of the SMD pickup nozzle should not exceed the size of the LED to prevent air leaks. The inner diameter of the nozzle should be as large as possible. A pliable material is suggested for the nozzle tip to avoid scratching or damaging the LED surface during pickup. The dimensions of the component must be accurately programmed in the pick-and-place machine to insure precise pickup and avoid damage during production.
5. LED operating environment and sulfur element composition cannot be over 100PPM in the LED mating usage material.





- 6. When we need to use external glue for LED application products, please make sure that the external glue matches the LED packaging glue. Additionally ,as most of LED packaging glue is silica gel, and it has strong Oxygen permeability as well as strong moisture permeability; in order to prevent external material from getting into the inside of LED, which may cause the malfunction of LED, the single content of Bromine element is required to be less than 900PPM,the single content of Chlorine element is required to be less than 900PPM,the total content of Bromine element and Chlorine element in the external glue of the application products is required to be less than 1500PPM
- 7. Please note that the electrostatic protection during processing › All devices, equipment and machinery must be properly grounded.

**Products using**

- 1. LED unfavorable use by constant voltage or more LED directly to the parallel use, advising clients to use in constant current mode.
- 2. When using LED products, please note that according to the grades of the same (voltage, brightness, color temperature) code together, different grades and different batches should be confirmed to meet customers' requirements to mix stick, lest produce color difference or brightness difference.

Product:S28351-IR850LR-01	Date: Nov 29th 2021	Page 7 of 9
	Version# 1.0	



**Reliability testing:**

NO	Item	Test Conditions	Time	Quantity	Ac/Re
1	IR-Reflow	TEMP : 245°C ± 5 °C	10 Sec	22 PCS	0/1
2	Temperature Cycle	H : +100°C 15min J 5 min L : -40°C 15min	300 Cycles	22 PCS	0/1
3	Thermal Shock	H : +100°C 5min J 10 sec L : -10°C 5min	300 Cycles	22 PCS	0/1
4	High Temperature Storage	TEMP : 100°C	1000 Hrs	22 PCS	0/1
5	Low Temperature Storage	TEMP : -40°C	1000 Hrs	22 PCS	0/1
6	DC Operating Life	TEMP : 25°C	1000 Hrs	22 PCS	0/1
		IF = 100mA			
7	High Temperature / High Humidity	85°C / 85% RH	1000 Hrs	22 PCS	0/1

**Criteria For Judging Damage**

Item	Symbol	Test Conditions	Criteria for Judgement	
			Min	Max
Forward Voltage	VF	IF=100mA		U.S.L*)x1.1
Reverse Current	IR	VR=5V		U.S.L*)x2.0
Luminous Flux	Im	IF=100mA	L.S.L*)x0.7	

**Part Numbering Code**

S	2835	1	IR	850	LR	01
SMD Type	Lead Frame Size	Chip qty	Color	Pd(watt)/nm/CCT	Chip Code	Version



S28351-IR850LR-01

PLCC2 INFRARED LED

## Revision History

Date	Changes/Reason of changes	Revision #



**Part Number Coding**

**CODING SCHEME**

<u>X</u>	<u>XXXX</u>	<u>X</u>	<u>X</u>	<u>XXX</u>	<u>X</u>	<u>XX</u>
S - SMD Type P - PCB Type L - Lamp Type HP - High Power Type M - LED Module Type F - Fixture Type	Lead Frame Size	Chip Qty	Emitting Color - W - White B - Blue S - Sensor N - Not visible	Pd(watt)/nm/CCT  Pd - 01 - 1W  nm (ref.) - 365 - 365nm 470 - 470nm 660 - 660nm  CCT - W - Warm White N - Netruel White C - Cool White	Chip Code	Version

**Note**

The information in this document provides generic information but for specific information on a product the appropriate product datasheet should be used.